



**INSTRUCTIONS**

**GEH-2059**

**RELAY FILE COPY**

**HB-7215**

# **TIME OVERCURRENT RELAYS**

HB-7215

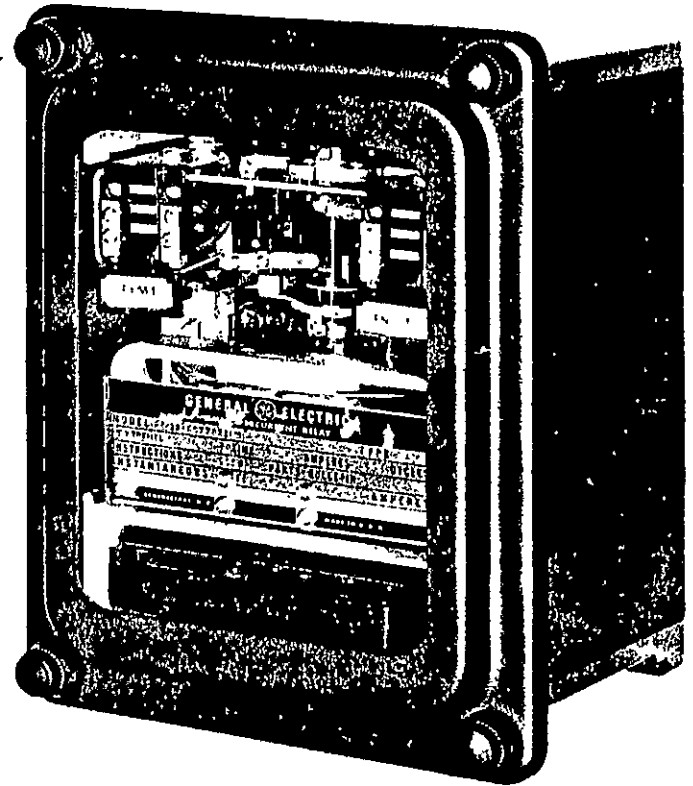

## **Types**

- IAC 77A Form 11 and Up**
- IAC 77B Form 31 and Up**
- IAC 78A Form 4 and Up**
- IAC 78B Form 11 and Up**

**SWITCHGEAR DEPARTMENT**

**GENERAL  ELECTRIC**

**PHILADELPHIA, PA.**

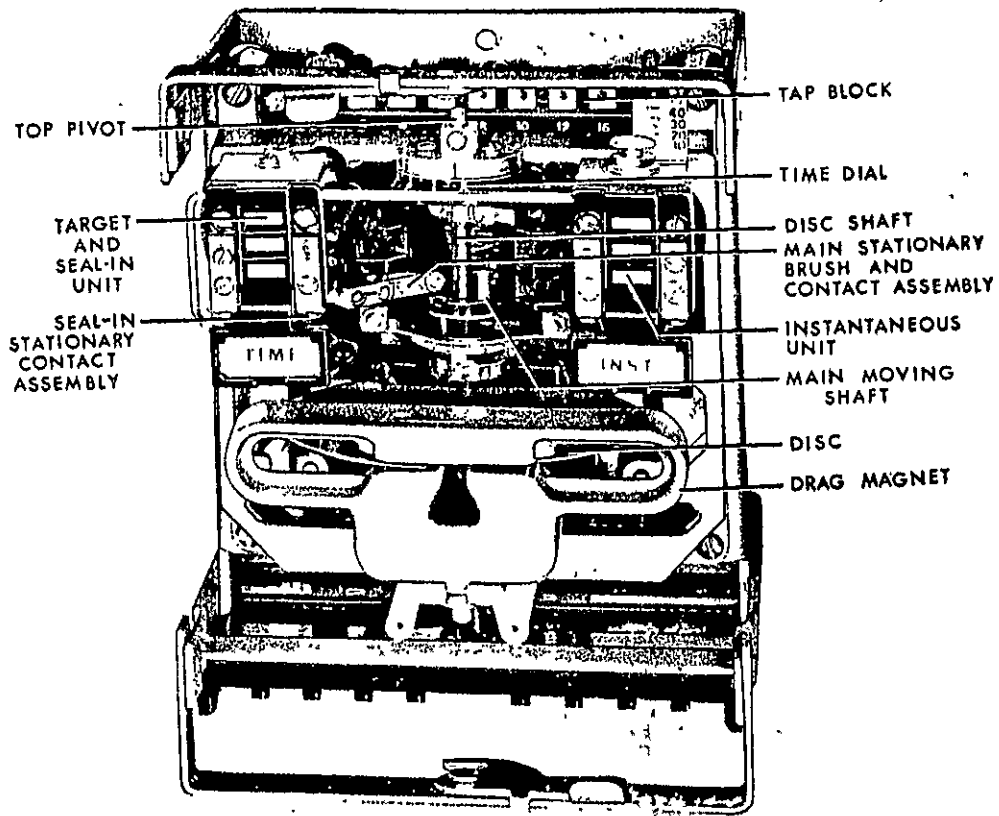

Fig. 1 (8035061) The Type IAC77B Relay Removed From Case (Front View)

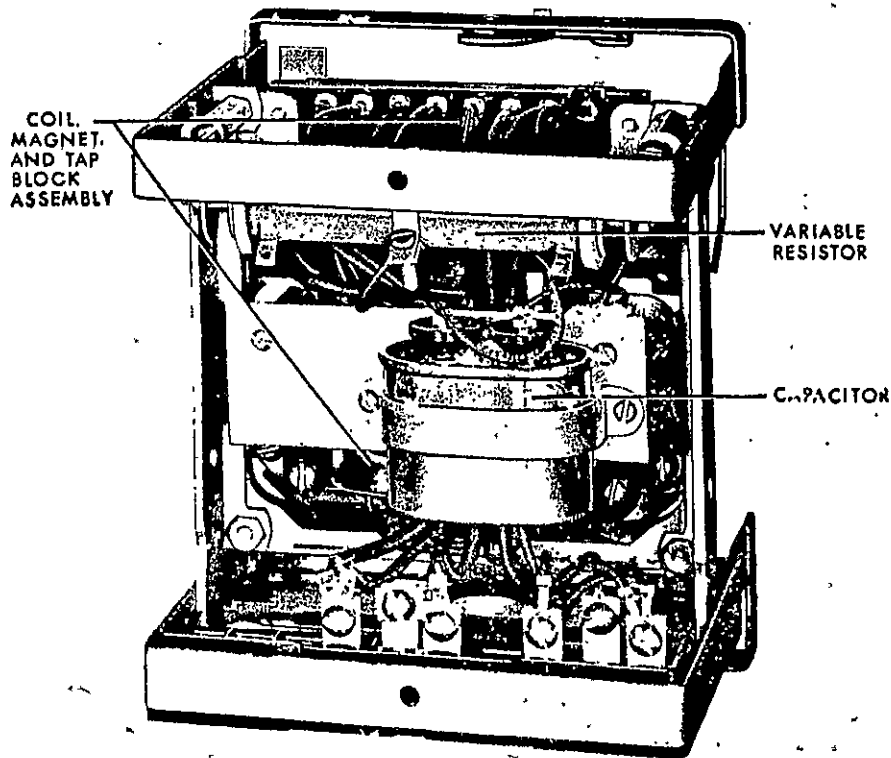

Fig. 1A (8035063) The Type IAC77B Relay Removed From Case (Rear View)

Cover (8035092)

# TIME OVERCURRENT RELAY TYPE IAC

## INTRODUCTION

These relays are of the induction disk construction with a wattmetric type current operating element. They have an extremely-inverse time-current characteristic as shown in Fig. 6.

## APPLICATION

The extremely inverse time current characteristics of the IAC77 and IAC78 relays make these relays particularly well suited for the protection of primary distribution feeder circuits.

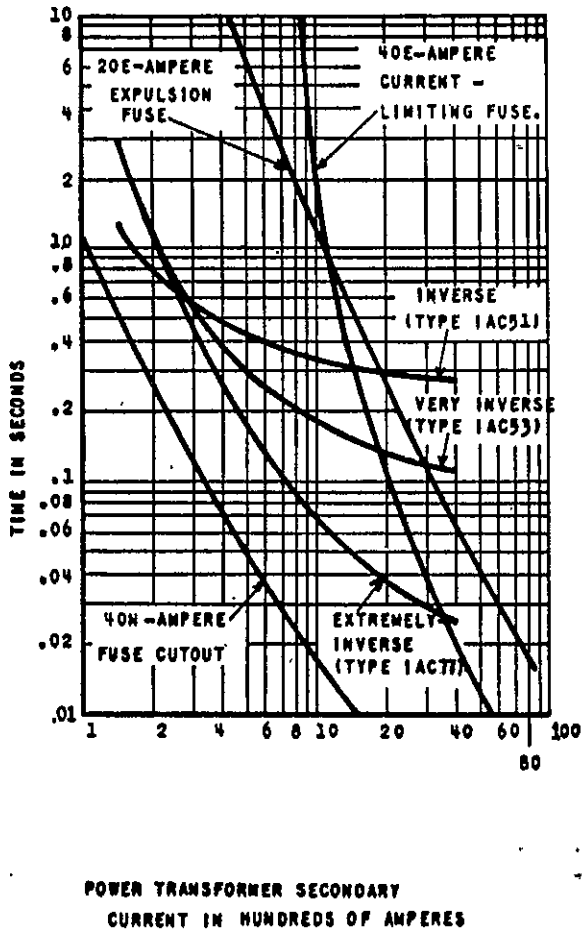

Fig. 2 (6507953-2) Comparison Of IAC Overcurrent Relay Characteristics Showing Co-ordination With Typical Primary And Secondary Fuses

In such applications, because the relay characteristics closely parallel those of power fuses, it is possible to obtain selective fault protection with a minimum time delay. For example, the system illustrated in Fig. 3, it is necessary that the protective relays (device 51) co-ordinate with the fuses on the high side of the power bank as well as with those on the load side of the power circuit breaker. Fig. 2 illustrates that this can be done most effectively with extremely inverse IAC77 or IAC78 relays whose characteristics most nearly parallel those of the fuses.

The extremely inverse relay also is better suited than both the inverse and very inverse relays for picking up cold load. For any given cold load pick up capability, the resulting settings will provide faster protection at high fault currents with the extremely inverse relay than with the less inverse relays.

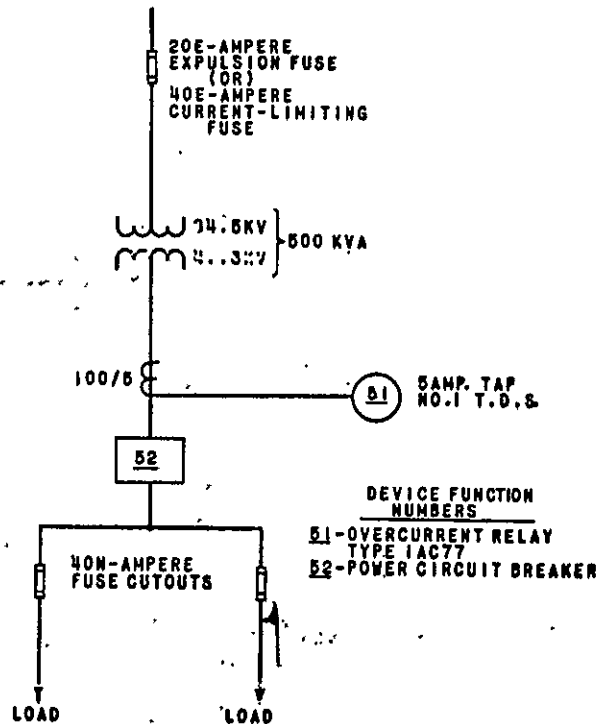

Fig. 3 (6507952-0) One-line Diagram Of Typical Distribution System Protected By Type IAC77 Time-Overcurrent Relay

These instructions do not purport to cover all details or variations in equipment nor to provide for every possible contingency to be met in connection with installation, operation or maintenance. Should further information be desired or should particular problems arise which are not covered sufficiently for the purchaser's purposes, the matter should be referred to the General Electric Company.

The zero current reset time of the extremely inverse IAC77 and IAC78 is approximately 60 seconds when set on time dial 10. For other time dial settings the zero current reset time is proportionately less. For example, the reset time from time dial 2 is approximately 12 seconds.

**RATINGS**

**INDUCTION UNIT**

Ratings of the induction unit are given in Table I:

**TABLE I**

Relay	Freq. Cycles	Current Oper. Range, Amperes	
		Main (time) Unit	Instantaneous Unit
IAC77A & IAC78A	60	4-16 1.5-6 0.5-2 0.1-0.4	
IAC77B & IAC78B	60	4-16 4-16 1.5-6 0.5-2	20-80 10-40 10-40 10-40

The 1 second thermal ratings are listed in Table II and IIA.

**TABLE II**

Induction Unit Rating (Amps)	1-Sec. Rating (Amps)
4-16	260
1.5-6	200
0.5-2	65
0.1-0.4	15

**TABLE IIA**

Rating	Taps Available
4-16	4, 5, 6, 7, 8, 10, 12, 16
1.5-6.0	1.5, 2.0, 2.5, 3.0, 4.0, 5.0, 6.0
0.5-2.0	0.5, 0.6, 0.8, 1.0, 1.2, 1.5, 2.0

**INSTANTANEOUS UNIT**

The instantaneous unit will withstand 1.5 times minimum pickup current. For example: The 10-40 instantaneous unit will withstand 1.5 x 10 or 15 amperes continuously.

**SEAL IN-UNIT**

Ratings of the seal-in unit are given in Table III.

**TABLE III  
SEAL-IN UNIT RATINGS**

	2 Amp Tap	0.2 Amp Tap
Carry-Tripping Duty	30 Amps	5 Amps
Carry Continuously	3 Amps	0.3 Amps
D-C Resistance	0.13 Ohms	7 Ohms
Impedance (60 cycles)	0.53 Ohms	52 Ohms

If the tripping current exceeds 30 amperes an auxiliary relay should be used, the connections being such that the tripping current does not pass through the contacts or the target and seal-in coils of the protective relay.

**CONTACTS**

The current-closing rating of the contacts is 30 amperes for voltages not exceeding 250 volts. The current-carrying rating is limited by the ratings of the seal-in unit.

**BURDENS**

Burdens for the induction unit coils are given in Table IV. These are calculated burdens at five amperes based on burden of minimum tap.

**TABLE IV**

Coil Rating	Freq.	Tap	VA	Z	PF
4-16	60	4	0.63	0.025	0.5
1.5-6	60	1.5	5.0	0.20	0.5
0.5-2	60	0.5	40.0	1.60	0.5
0.1-0.4	60	0.1	1050	42	0.5

The instantaneous unit burdens at 5 amps are listed in Table V.

**TABLE V**

Coil Rating	Freq.	Unit Setting	VA	Z	PF
10-40	60	10	0.83	.033	.95
20-80	60	20	0.21	.008	.95

**RECEIVING, HANDLING AND STORAGE**

These relays, when not included as a part of a control panel, will be shipped in cartons designed to protect them against damage. Immediately upon receipt of the relay, an examination should be made for any damage sustained during shipment. If injury or damage resulting from rough handling is evident, a claim should be filed at once with the transportation company and the nearest Sales Office of the General Electric Company notified promptly.

Reasonable care should be exercised in unpacking the relay in order that none of the parts are injured or the adjustments disturbed.

If the relays are not to be installed immediately, they should be stored in their original cartons in a place that is free from moisture, dust, and

metallic chips. Foreign matter collected on the outside of the case may find its way inside when the cover is removed and cause trouble in the operation of the relay.

**DESCRIPTION**

These relays consist of an induction unit, seal-in unit, and in some types an instantaneous unit, all assembled with their associated parts in a S1 Case.

**RELAY TYPES**

The Type IAC77A relay has single-circuit closing contacts. The contacts close as the current increases to pickup value as set on the tap block. The time delay in closing the contacts is determined by the setting of the time dial at the top of the disk shaft.

The Type IAC77B relay is similar to the Type IAC77A relay except that it has in addition an instantaneous unit.

The Type IAC78A relay is similar to the Type IAC77A relay except that it has two-circuit closing contacts.

The Type IAC78B relay is similar to the IAC77B relay except that it has two circuit closing contacts.

**INDUCTION UNIT**

The disk is actuated by a wattmetric type current operating element. This is similar to the standard element as used in watt-hour meters, except the actuating coils above and below the operating disk are connected in series. A capacitor

and variable resistor connected in series with the inner coil on the upper laminated structure make up the phase-shifting circuit. The disk shaft carries the moving contact which completes the trip or alarm circuit when it touches the stationary contact or contacts. The disk shaft is restrained by a spiral spring to give the proper contact closing current and its motion is retarded by a permanent magnet acting on the disk to give the correct time delay.

**SEAL-IN UNIT**

A seal-in unit is mounted to the left of the shaft as shown in Fig. 1. This unit has its coil in series and its contacts in parallel with the main contacts such that when the main contacts close, the seal-in unit picks up and seals in. When the seal-in unit picks up, it raises a target into view which latches up and remains exposed until released by pressing a button beneath the lower left corner of the cover.

**INSTANTANEOUS UNIT**

The instantaneous unit is a small instantaneous hinge-type unit which may be mounted on the right front side of the induction unit (see Fig. 1). Its contacts are normally connected in parallel with the contacts of the main unit. Its coil is connected in series with the operating coil of the main unit.

When the current reaches a predetermined value, the instantaneous unit operates, closing the contact circuit and raising its target into view. The target latches in the exposed position until released by pressing the button beneath the lower left-hand corner of the relay cover.

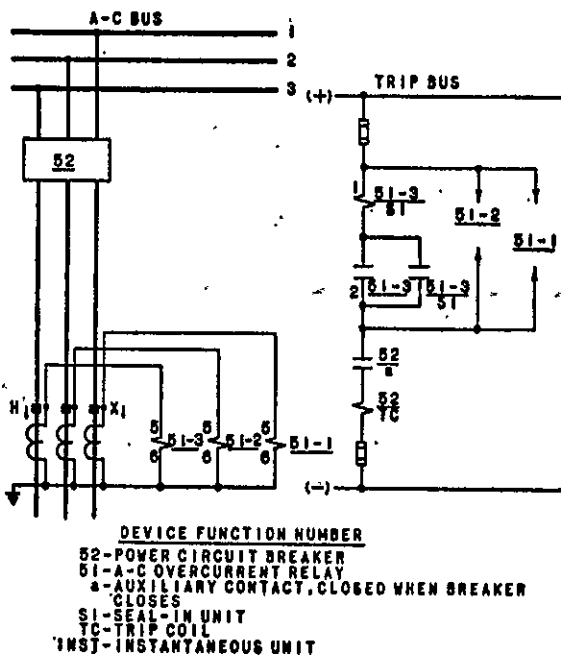

Fig. 4 (6507951-0) Elementary Diagram, Type IAC77A Relays Protecting Three-Phase Circuit

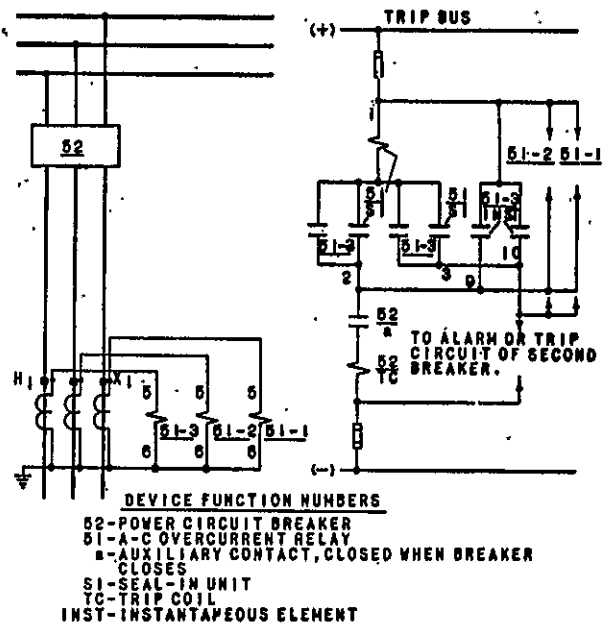
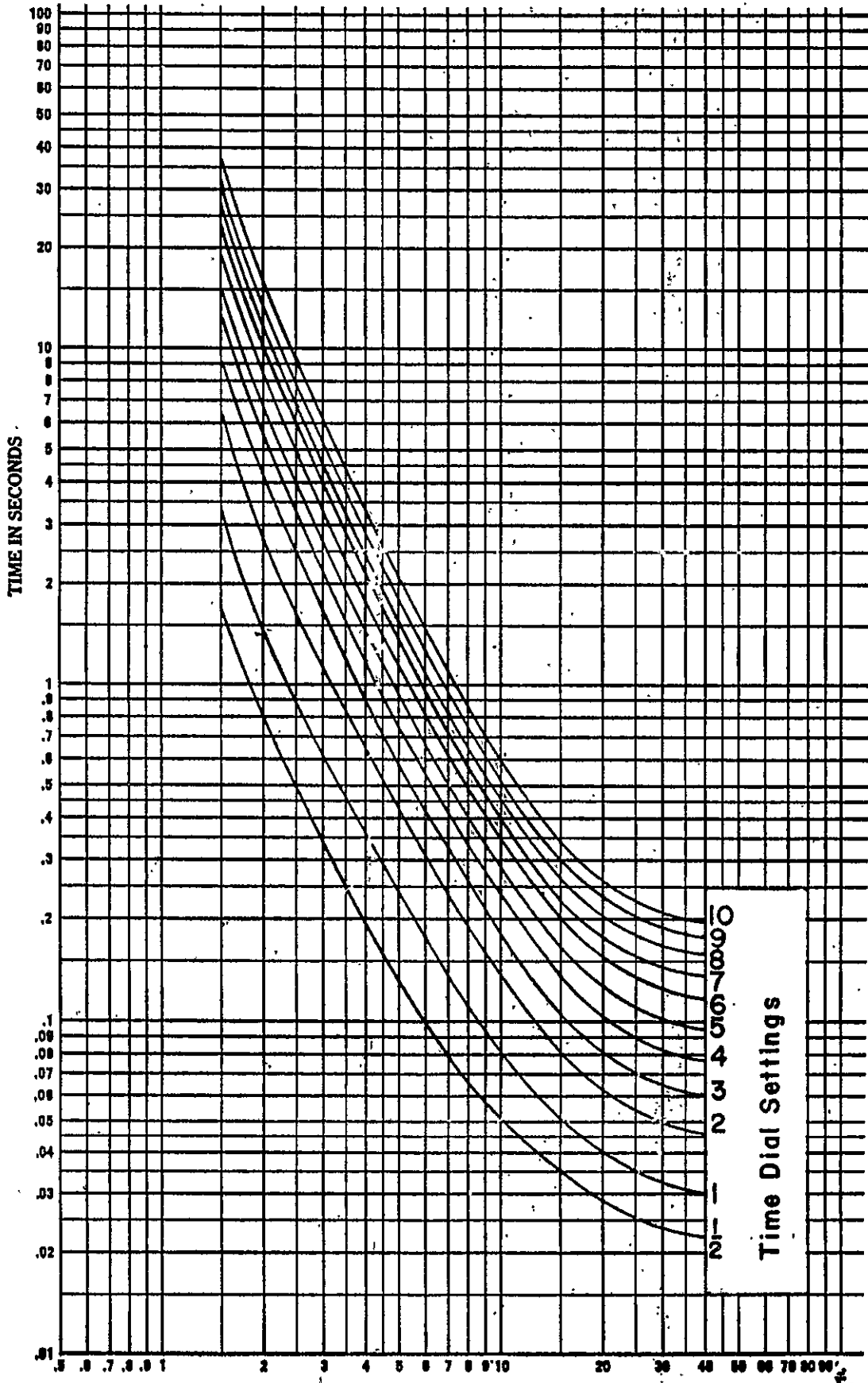

Fig. 5 (6507950-0) Elementary Diagram Type IAC78B Relay For Tripping Two Circuit Breakers



**MULTIPLES OF RELAY TAP SETTING**

Fig. 6 (0888B0274-1) Time-current Characteristic For Type IAC77 And IAC78

The instantaneous unit operates over a 4 to 1 range and has its calibration stamped on a scale mounted beside the adjustable pole piece.

## INSTALLATION

### LOCATION

The location should be clean and dry, free from dust and excessive vibration, and well lighted to facilitate inspection and testing.

### MOUNTING

The relay should be mounted on a vertical surface. The outline and panel diagrams are shown in Figs. 14 and 15.

### CONNECTIONS

Internal connection diagrams for the various relay types are shown in Fig. 10 to 13 inclusive. Typical wiring diagrams are given in Fig. 4 and 5.

One of the mounting studs or screws should be permanently grounded by a conductor not less than No. 12 B&S gage copper wire or its equivalent.

### CAUTION:

Every circuit in the drawout case has an auxiliary brush. It is especially important on current circuits and other circuits with shorting bars that the auxiliary brush be bent high enough to engage the connecting plug or test plug before the main brushes do. This will prevent CT secondary circuits from being opened.

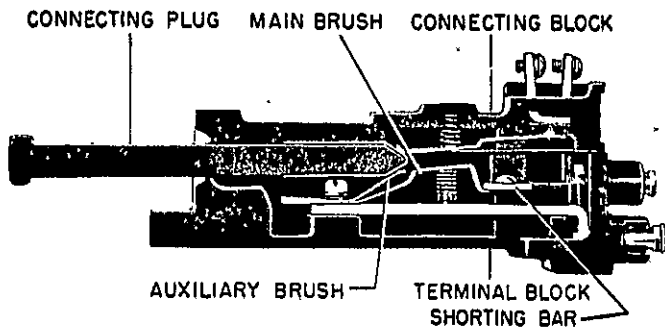

NOTE: AFTER ENGAGING AUXILIARY BRUSH, CONNECTING PLUG TRAVELS 1/4 INCH BEFORE ENGAGING THE MAIN BRUSH ON THE TERMINAL BLOCK

Fig. 7 (8025039) Cutaway Of Drawout Case Showing Position Of Auxiliary Brush And Shorting Bar

## ADJUSTMENTS

### INDUCTION UNIT

The minimum current at which the contacts will just close is determined by the position of the tap screw in the tap block at the top of the relay.

When changing the current setting of the relay while in the case, remove the connection plug to

short the current transformer secondary circuit. Next, screw the tap screws into the tap marked for the desired current and then replace the connection plug.

The pickup of the unit for any current tap setting is adjusted by means of the variable resistor in the phase-shifting circuit. This adjustment also permits any desired setting intermediate between the various tap settings to be obtained. The control spring is prewound approximately 660 degrees with the contacts just closed. Further adjustment of this setting is seldom required. The unit is adjusted at the factory to close its contacts from any time-dial position at a minimum current within five per cent of the tap setting. The unit resets at 85 per cent of the minimum closing value.

### TIME SETTING

The setting of the time dial (see Fig. 1) determines the length of time the unit requires to close its contacts when the current reaches the predetermined value. The contacts are just closed when the dial is set on 0. When the dial is set on 10, the disk must travel the maximum amount to close the contacts, this gives the maximum time setting.

The primary adjustment for the time of operation of the unit is made by means of the time dial. Further adjustment is obtained by moving the magnet along its supporting shelf. Moving the magnet in toward the back of the unit decreases the time, while moving it away increases the time.

If selective action of two or more relays is required, determine the maximum possible short-circuit current of the line and then choose a time value for each relay that differs sufficiently to insure the proper sequence in the operation of the circuit breakers. Allowance must be made for the time involved in opening each breaker after the relay contacts close. For this reason, unless the circuit time of operation is known with accuracy, there should be a difference of about 0.5 second (at the maximum current) between relays whose operation is to be selective.

### EXAMPLE OF SETTING

The time and current settings of the induction unit can be made easily and quickly. Each time value shown in Fig. 6 indicates the time required for the contacts to close with a particular time-dial setting when the current is a prescribed number of times the current-tap setting. In order to secure any of the particular time-current settings shown in Fig. 6, insert the tap screw in the proper tap and adjust the time dial to the proper position. The following example illustrates the procedure in making a relay setting.

Assume a Type IAC77 relay is used in a circuit where the circuit breaker should trip on a sustained current of approximately 400 amperes; also, the breaker should trip in 0.5 seconds on a short-circuit current of 3750 amperes. Assume further that current transformers of 60/1 ratio are used.

**GEH-2059 Time Overcurrent Relays Type IAC**

The current-tap setting is found by dividing the minimum primary tripping current by the transformer ratio. In this case, 400 divided by 60 equals 6.8 amp. Since there is a 7.0 ampere tap, set the relay in this tap. To find the proper time-dial setting to give 0.5 seconds time delay at 3750 amperes, divide 3750 by the transformer ratio. This gives 62.5 amperes secondary current which is 8.95 times the 7-ampere setting. By referring to the time-current curves Fig. 6, it will be seen that 8.95 times the minimum operating current gives 0.5 seconds time delay when the relay is set slightly above the No. 7 time-dial setting.

The above results should be checked by means of an accurate timing device as shown in Fig. 8. Slight readjustment of the dial can be made until the desired time is obtained.

Aid in making the proper selection of relay settings may be obtained by applying to the nearest Apparatus Sales Office of the General Electric Company.

**INSTANTANEOUS UNIT**

Select the current above which it is desired to have the instantaneous unit pickup. Loosen the locknut and turn the pole piece up or down so that the top of the hexagonal head will be even with the selected current mark on the calibrated scale; then tighten locknut.

The contacts should be adjusted to make at about the same time and to have approximately 1/32" wipe. This adjustment can be made by

loosening the screws holding the stationary contacts and moving the contacts up or down as required. The time-current characteristic of the instantaneous unit is given in Fig. 9.

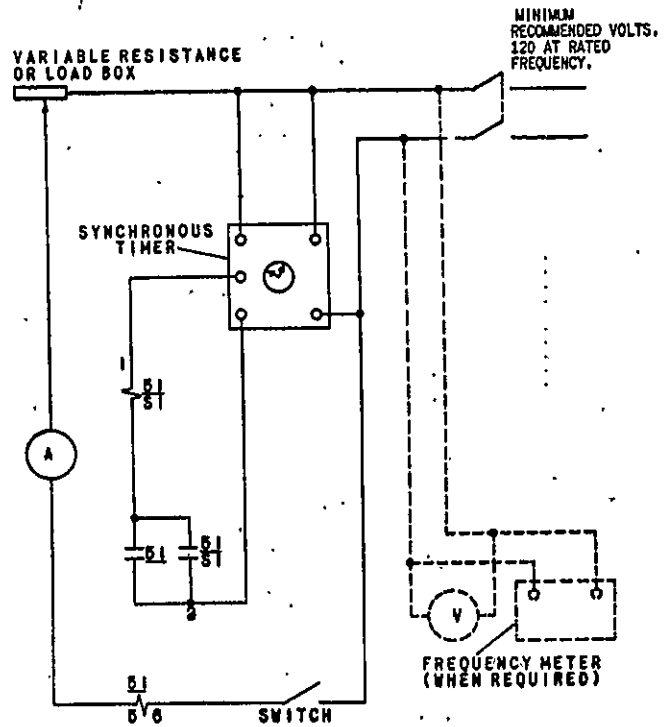

Fig. 8 (6154399-5) Connections For Testing Single-phase IAC Relay (Front View)

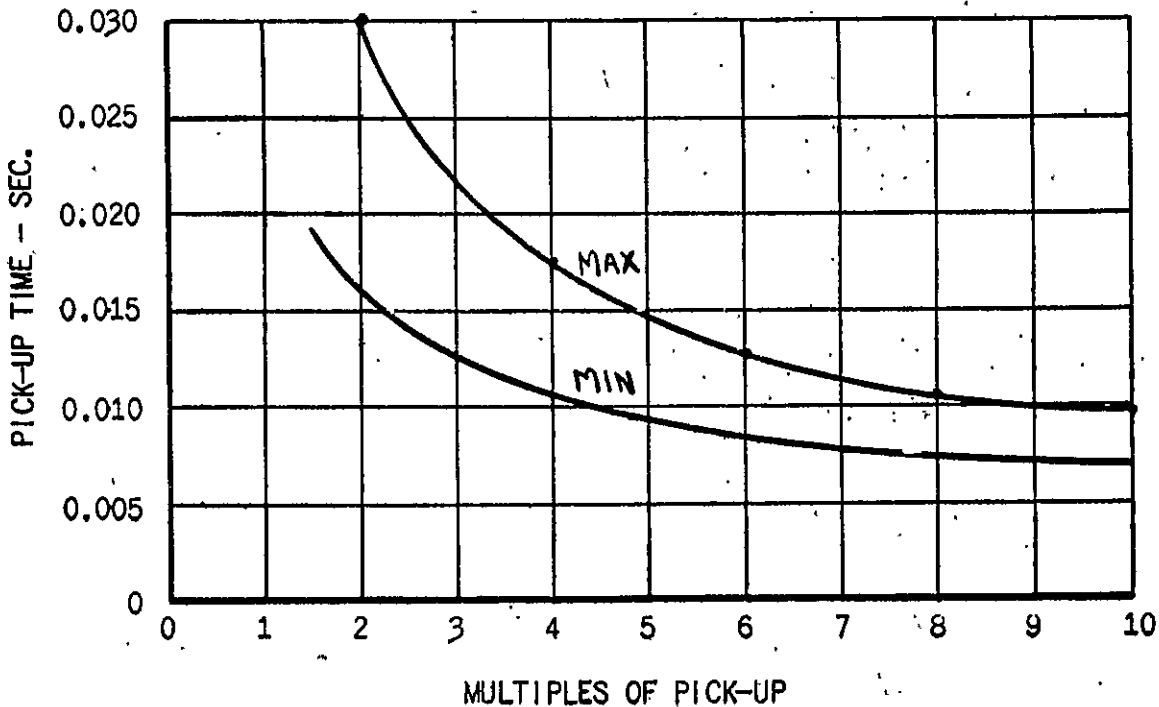
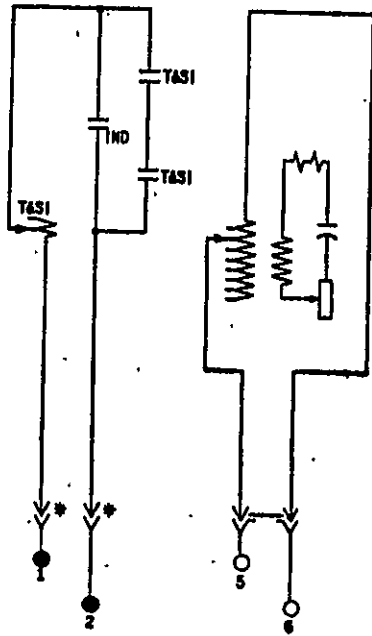

Fig. 9 (6306872-3) Time-Current Curve Of Instantaneous Unit





◆ = SHORT FINGERS

Fig. 10 (0165A7758-0) Type IAC77A Relay Internal Connections (Front View)

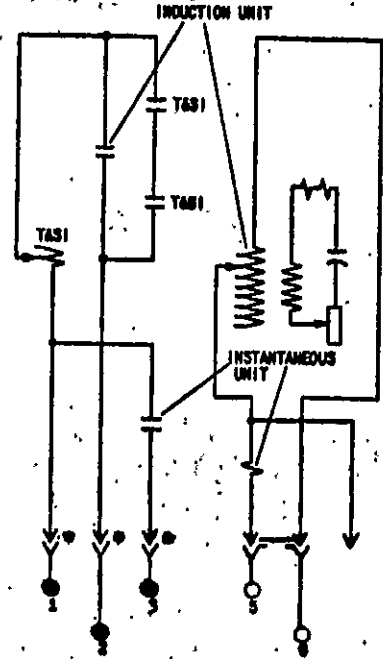

◆ = SHORT FINGERS

Fig. 11 (0165A7759-0) Type IAC77B Relay Internal Connections (Front View)

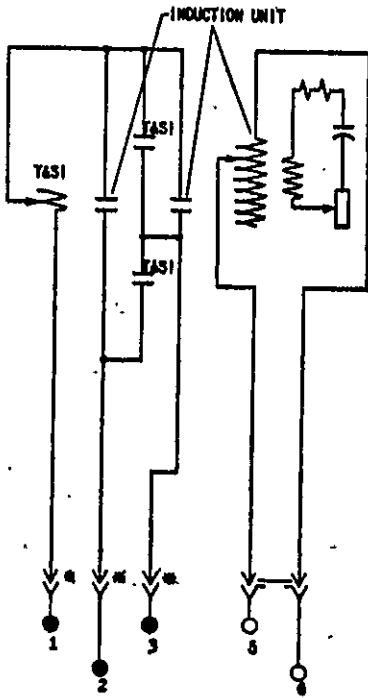

◆ = SHORT FINGER

Fig. 12 (0165A7781-0) Type IAC78A Relay Internal Connections (Front View)

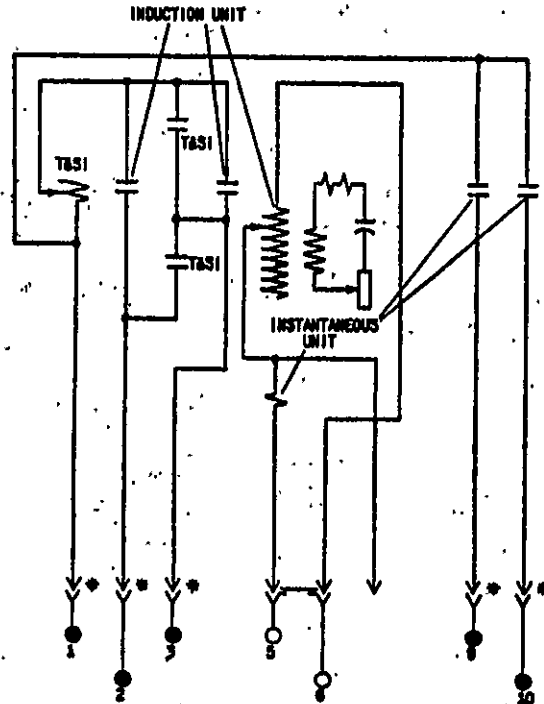

◆ = SHORT FINGER

Fig. 13 (0165A7782-0) Type IAC78B Relay Internal Connections (Front View)

## TARGET AND SEAL-IN UNIT

For trip coils operating on currents ranging from 0.2 up to 2.0 amperes at the minimum control voltage, set the target and seal-in tap plug in the 0.2-ampere tap.

For trip coils operating on currents ranging from 2 to 30 amperes at the minimum control voltage, place the tap screw in the 2-ampere tap.

The tap screw is the screw holding the right-hand stationary contact of the seal-in unit. To change the tap setting, first remove the connecting plug. Then, take a screw from the left-hand stationary contact and place it in the desired tap. Next remove the screw from the other tap, and place it in the left-hand contact. This procedure is necessary to prevent the right-hand stationary contact from getting out of adjustment. Screws should not be in both taps at the same time.

## MAINTENANCE

The relays are adjusted at the factory and it is advisable not to disturb the adjustments. If for any reason, they have been disturbed, the section ADJUSTMENTS should be followed in restoring them.

## DISK AND BEARINGS

The lower jewel may be tested for cracks by exploring its surface with the point of a fine needle. If it is necessary to replace the jewel a new pivot should be screwed into the bottom of the shaft at the same time. The jewel should be turned up until the disk is centered in the air gaps, after which it should be locked in this position by the set screw provided for this purpose. The upper bearing pin should next be adjusted until very little end play can be felt between the pin and the steel ball in the recess at the top of the shaft; about 0.015 inch is correct.

## CONTACT CLEANING

For cleaning fine silver contacts, a flexible burnishing tool should be used. This consists of a flexible strip of metal with an etched roughened surface, resembling in effect a superfine file. The polishing action is so delicate that no scratches are left, yet corroded material will be removed rapidly

and thoroughly. The flexibility of the tool insures the cleaning of the actual points of contact.

Fine silver contacts should not be cleaned with knives, files, or abrasive paper or cloth. Knives or files may leave scratches which increase arcing and deterioration of the contacts. Abrasive paper or cloth may leave minute particles of insulating abrasive material in the contacts and thus prevent closing.

The burnishing tool described is included in the standard relay tool kit obtainable from the factory.

## PERIODIC TESTING

An operation test and inspection of the relay at least once every six months are recommended. Test connections are shown in Fig. 8.

## RENEWAL PARTS

It is recommended that sufficient quantities of renewal parts be carried in stock to enable the prompt replacement of any that are worn, broken, or damaged.

When ordering renewal parts, address the nearest Sales Office of the General Electric Company, specify quantity required, name of part wanted, and give complete nameplate data. If possible, give the General Electric Company requisition number on which the relay was furnished. The renewal parts publication is GEF-3883.

## ACCEPTANCE TESTS (ELECTRICAL)

### A. MAIN UNIT

Pickup - Set relay at 0.5 t.d. and minimum tap contacts should close within  $\pm 5\%$  of tap value.

Time test - Set relay at 5.0 t.d. and minimum tap and apply 5X tap value. Relay should operate within  $\pm 5\%$  of 0.93 seconds.

### B. INSTANTANEOUS UNIT

Pickup - With current suddenly applied unit should operate within  $\pm 10\%$  of minimum rating.

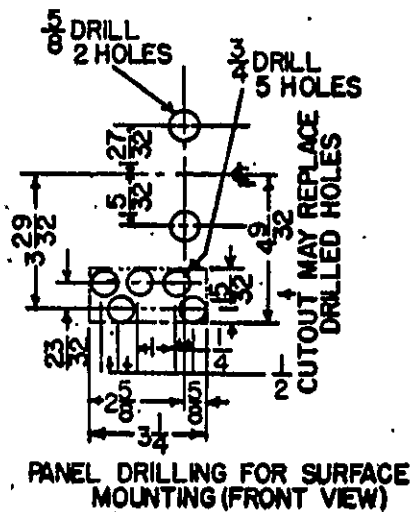
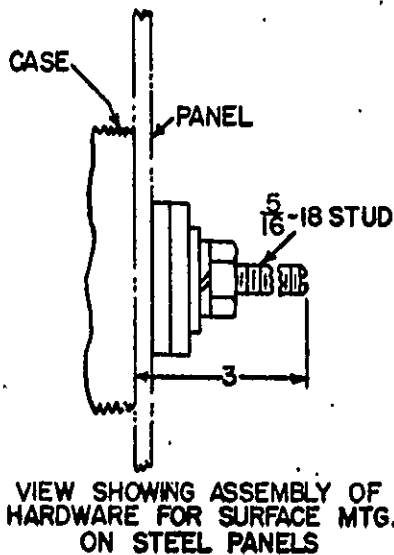
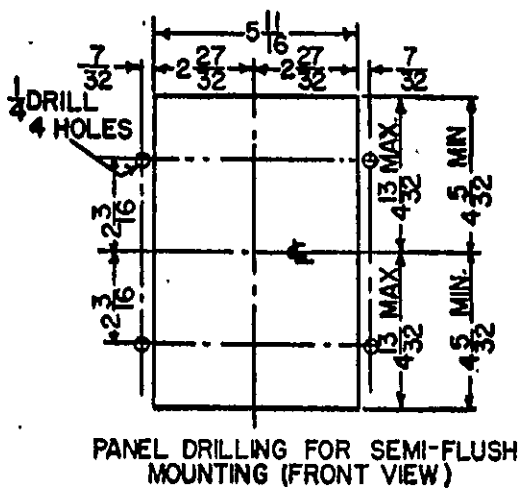
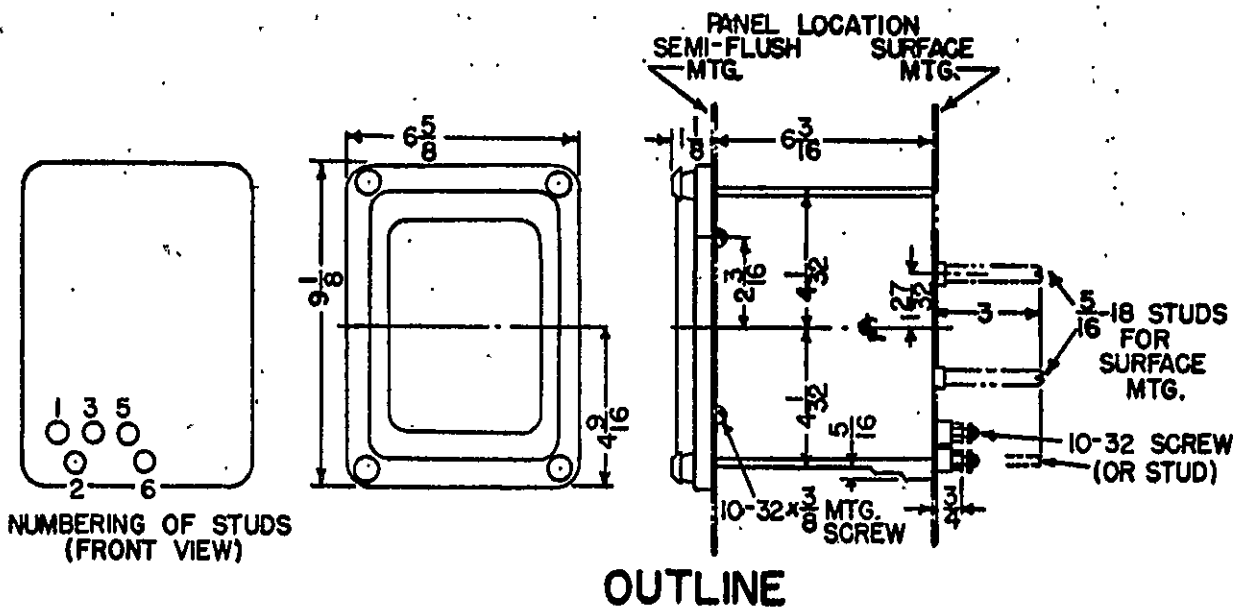

Fig. 14 (6209270-2) Outline And Panel Drilling For Relay Types IAC77A, IAC77B And IAC78A

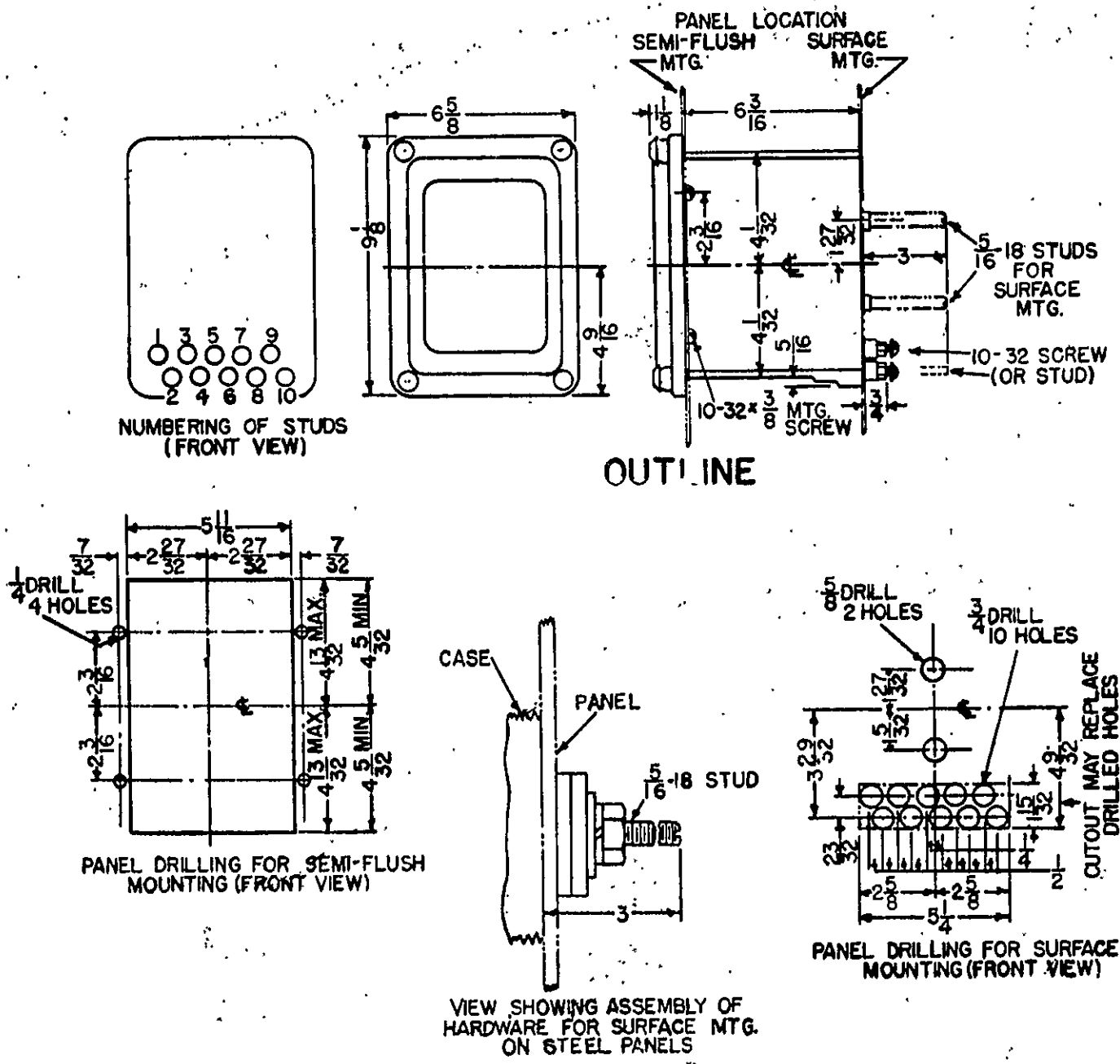

Fig. 15 (6209271-3) Outline And Panel Drilling For IAC78B